

Morphological characteristics and biodiversity of mudskipper fish (*Periophthalmus: Gobiidae*) in mangrove ecosystem of coastal Bay of Tomini, Boalemo, Gorontalo Province, Indonesia

DEWI WAHYUNI K. BADERAN^{1,2,*}, REGINA VALENTINE AYDALINA¹, MARINI SUSANTI HAMIDUN¹

¹Department of Biology, Faculty of Mathematics and Natural Sciences, Universitas Negeri Gorontalo. Jl. Prof. B.J. Habibie, Moutong, Bone Bolango 96583, Gorontalo, Indonesia. Tel.: +62-435-821125, Fax.: +62-435-821752, *email: dewi.baderan@ung.ac.id

²Wallacea Research Centre for Biodiversity Conservation and Climate Change, Universitas Negeri Gorontalo. Jl. Jend. Sudirman No. 6, Kota Gorontalo 96128, Gorontalo Province, Indonesia

Manuscript received: 21 September 2022. Revision accepted: 22 January 2023.

Abstract. Baderan DWK, Aydalina RV, Hamidun MS. 2023. Morphological characteristics and biodiversity of mudskipper fish (*Periophthalmus: Gobiidae*) in mangrove ecosystem of coastal Bay of Tomini, Gorontalo Province, Indonesia. *Biodiversitas* 24: 498-507. The southern sea area of Gorontalo Province is part of Tomini bay, the biggest bay in Indonesia. This area has a unique biodiversity and is Sulawesi endemic. The mangrove forest in the coastal bay of Tomini Boalemo is one of the habitats for flora and fauna, a place for spawning, nurturing, and food hunting for fish. The mudskipper is a fish that lives in the mangrove area. This study aims to reveal the morphological characteristics and biodiversity of mudskipper (*Periophthalmus: Gobiidae*) in the ecosystem of Tomini Boalemo coastal bay of Gorontalo Province. This study employed a quantitative descriptive that also implemented purposive sampling as the sampling method in three ecosystem stations of Tomini Boalemo coastal bay (Dulupi, Bajo, and East Pentadu mangrove). The mudskippers were collected manually when the water was receding using a fish net. The sample which had been collected were then identified based on 22 morphological, 24 morphometric, and seven meristic characteristics. The identification results were then compared with the identification key. The mudskippers' species were then analyzed to determine the species' biodiversity (diversity, evenness, species richness, and dominance indexes). The research result revealed five species from *Periophthalmus* Genus: *Periophthalmus argentilineatus*, *Periophthalmus kalolo*, *Periophthalmus malaccensis*, *Periophthalmus minutus*, *Periophthalmus variabilis*, with total individuals 561. The score of H' : 1.09 showed that the diversity of mudskipper fish was categorized as medium. The evenness index was 0.99 obtained from 3 observation stations, while the lowest dominance index was on station II with a score of 0.34, and the score of R_1 in each station was respectively (0.19); (0.36); and (0.2). The results of this study could be used as a database for the sustainable management of Tomini Bay to tackle the threats of species extinction through aquatic life protection and preservation to arrange the natural balance and support the availability of the coastal resource for future generations.

Keywords: Biodiversity, meristics, morphology, *Periophthalmus*, Tomini Bay

INTRODUCTION

Tomini Bay is the largest bay in Indonesia and is located in the coral triangle initiative. One of the parts of the bay which has rich biodiversity is the mangrove ecosystem which plays an important role in improving coastal sea productivity, spawning area, and nutrient supply needed by various species of fish (Nguyen and Parnel 2017; Lapolo et al. 2018), and potential of biodiversity (Cooray et al. 2021). In addition, Sellang (2020) stated that the mangrove ecosystem is one of the most important and productive environments for fish species in tropical areas and subtropical estuaries, which can improve the fertility and productivity of the coastal area. Mudskipper fish (Perciformes: Gobiidae) is one of the families that live in the mangrove ecosystem, as mentioned by Latuconsina (2016) and Rha'ifa et al. (2021) as the local resident of the mangrove ecosystem. One of the Genera that belongs to the Family widely distributed in that ecosystem is *Periophthalmus* (WoRMS 2018; Fishbase 2022). This Genus occupies primary (organisms that obtain energy from producers) and secondary positions (organisms that obtain energy from

primary consumers) in the food chain despite their very small size (Polgar et al. 2017), inhabiting muddy habitats, sandy beaches, and mangrove areas (Mahadevan and Ravi 2015). Mudskippers' daily behavior is closely related to tidal rhythm (Ravi 2013), where they climb mangrove roots, walk on mudflats, and dig burrows in mud (Ansari et al. 2014; Hui et al. 2019; Hidayat et al. 2022).

The mudskipper fish has various species, yet they have numerous similarities in terms of morphology (Ridho et al. 2019). One of its unique characteristics is spending 90% of its life a day living on land, climbing, and perching on the roots of the mangrove or wood, and being able to crawl up on the land (Mukharomah et al. 2016). Its pectoral fin on its muscular base can be buckled to function like an arm used to crawl, jump above the mud, and attach to rocks and open roots (Huang 2013; Wicaksono et al. 2016). The potential of mudskipper fish as the filter feeder that consumes the organic particles of living creatures suspended in water can absorb Lead (Pb) and has a role as a bio-indicator of environmental pollution (Akinrotimi et al. 2012). People can use the mudskipper to fulfill their food needs because it has a high nutritional value (Akinrotimi et al. 2012; Bidawi et al.

2017). *Boleophthalmus boddarti*, one of the mudskipper fish species, has a high value of fat in the liver (554.45 ± 4.49 mg/g), protein (3.5 ± 0.35 mg/100mg), and 1.5 ± 0.47 mg/100 mg protein in the muscle (Kanejiya et al. 2017). Mudskipper fish also have economic value in several countries in Asia. For instance, mudskipper with beautiful morphological characters can be used as ornamental fish in China, Japan, and Korea. They are generally sold as preserved products in Indonesia, such as dried and smoked fish (Faridah-Hanum et al. 2014). Besides, mudskipper, as the native residents of mangrove habitats, creates a natural view awaited by tourists (Chakraborty et al. 2020).

One of the areas in Sulawesi Island directly borders Tomini Bay is Boalemo Regency. Boalemo generally has a typical characteristic of a coastal area with relatively high resources, particularly in the mangrove forest and fishery sources, one of which is the mudskipper fish. Therefore, the existence of this fish in the mangrove ecosystem in the Coastal Bay of Tomini Bualemo is pretty abundant. However, it is disregarded as fishermen and people in Boalemo are unaware of the potential of the nutrition consisted in the mudskipper fish. Consequently, the existence of the mudskipper fish in the Mangrove Coast Tomini Bay is threatened to be extinct along with the decrease of its population. That extinction aligns with the speed of mangrove forest degradation. The main cause of the degradation is the land conversion in mangrove forests to become fish and shrimp ponds. That is affirmed by Hai et al. (2020), that mangrove is an important component of the coastal ecosystem which is severely and globally threatened by various causing factors. In 1988, the mangrove forest area in Tomini Bay was noted as big as 17,672 hectares, while in 2010, it was degraded to 16,105 hectares, and in 2020, it is predicted to have the remaining area as big as 10,321 hectares (Paino 2020).

The mudskipper species identified until today are around 43 species in 10 genera (Polgar et al. 2013; Rupp 2021). General information about mudskipper fish has been available, yet its species in Tomini Bay have not been found. Even the people in the coastal Bay of Tomini Bualemo stated that the mudskipper fish is poisonous. People have not yet known the potential use of the mudskipper fish optimally in terms of ecology, economy, and health, so this research is urgent. This research aims to analyze the morphological characteristics and biodiversity of mudskipper fish as the reliable resident of the mangrove area in Tomini Bay. The findings of this research can be used as support for formulating policies that aim to minimize the mangrove degradation in the coastal bay of Tomini.

MATERIALS AND METHODS

Study area

This study was carried out in a mangrove ecosystem in the coastal bay of Tomini, Boalemo, Gorontalo Province. It included three observation stations, i.e., station I (Dulupi Village, N $00^{\circ}30.640$, E $122^{\circ}26.982$), station II (Bajo Village, N $00^{\circ}29.818$, E $122^{\circ}20.931$), and station III (East Penatdu Village, N $00^{\circ}30.736$, E $122^{\circ}22.336$). The three sampling locations were chosen because they have healthy mangrove forests. This study was conducted for five months, from May to September 2022. This study employed a descriptive quantitative method by implementing a purposive sampling method in three stations of the mangrove ecosystem in the coastal bay of Tomini, Boalemo. The data collected were primary and secondary data. The primary data were collected by identifying all species of the mudskipper fish and some of its morphological, morphometrical, and meristic characteristics, as well as its biodiversity (diversity, evenness, and species richness indexes) (Figure 1).

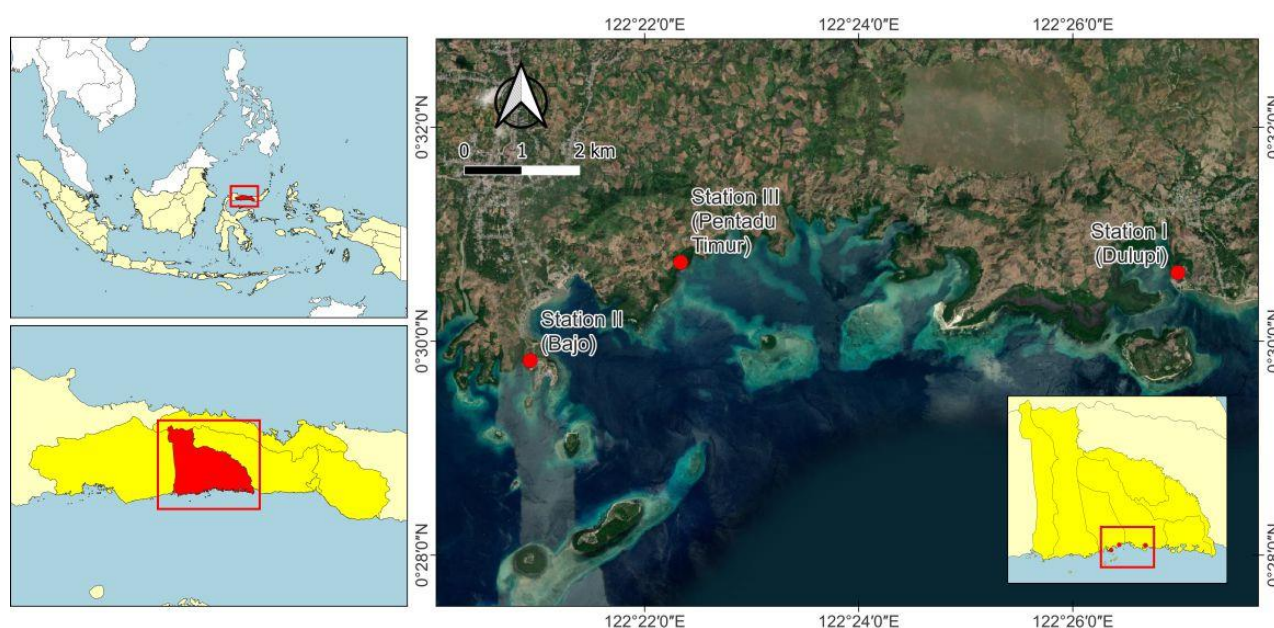

Figure 1. Location of the coastal bay of Tomini, Boalemo, Gorontalo Province, Indonesia, indicating the sampling sites of *Periophthalmus*, i.e.: station I (Dulupi Village), station II (Bajo Village), and station III (East Penatdu Village)

Tools and materials

The tools used were a scoop net, a 3x3 sq. meters fish net, a cool box, a zip lock, stationery, a digital camera, ruler, millimeter block paper, gloves, jar, GPS, thermometer, pH meter, and an Ohaus digital scale with an accuracy of 0.01 g. The materials used were mudskipper fish, 10% formalin, 70% alcohol, tracing paper, ice, sewing thread, and distilled water.

Procedures

The sampling procedures are as follows: (i) Specimen collection using a 3x3 meters net and hand-collecting in 3 locations of the mangrove ecosystem of the coastal area of Tomini bay; (ii) Measurement of physical-chemical factor temperature, substrate, water pH, and substrate pH of the environment was done in every location; (iii) Observations and measurements of physical factors are carried out during the day when the sea recedes; (iv) The specimen was put in a jar, labeled, and then transferred to the laboratory for identification purposes; (v) Specimen documentation was carried out utilizing a Nikon DX VR camera with an AF-S NIKKON 18-55 mm lens and a Macro Pro Tama Digital PRO 0.45X HD WIDE LENS SDW-045 52 mm; (vi) The mudskipper fish samples were observed and measured for morphological, morphometric and meristic characterization in the Biology Laboratory, Faculty of Mathematics and Natural Sciences, and the Agricultural Laboratory, Faculty of Agriculture, Universitas Negeri Gorontalo. This observation and measurement step was referred to (Larson and Murdy 2001; Polgar et al. 2013; Maryam et al. 2015; Aydalina 2016; Ghanbarifardi et al. 2018; Kaur et al. 2019; Mahadevan et al. 2019; Gonzalez-Martinez et al. 2020). Species identification was carried out by referring to (Murdy 1989; Larson and Murdy 2001; Jaafar et al. 2016) (Figure 2). Specimen fixation used 70% alcohol and 10% formalin.

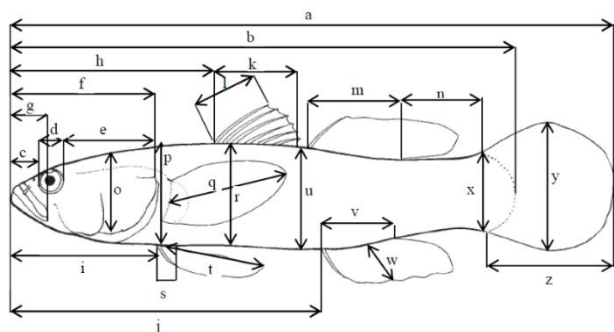

Figure 2. Morphometric characterization scheme of the mudskipper: a. total length; b. standard length; c. Pre-orbital length; d. eye diameter; e. post-orbital length; f. post-orbital length; g. mouth length; h. pre-dorsal length; i. pre-ventral length; j. pre-anal length; k. first dorsal fin base length; l. height of the longest first spiny dorsal fin; m. second dorsal fin base length; n. length of caudal peduncle; o. head height; p. front body height; q. length of the longest spiny pectoral fin; r. middle body height; s. middle body height; t. length of the longest spiny pelvic spin; u. caudal fin height; v. anal fin base length; w. length of the longest spiny anal fin; x. Caudal peduncle depth; y. caudal fin height; z. caudal fin length (Larson and Murdy 2001; modified by authors)

Data analysis

Morphometric and meristics data were analyzed using the Microsoft Excel program, and morphological observations were analyzed descriptively.

Data on the diversity of mudskipper species were analyzed using the Diversity Index (H') (Shannon and Wiener 1963; Fachrul 2012). $H' = -\sum_{i=1}^S p_i \ln p_i$ where $p_i = \frac{n_i}{N}$. H' represents the Shannon-Wiener Diversity index, S for total species, N_i for total individuals in a species, \ln for the natural algorithm, and N for total individuals found. The value of H' determines the level of species diversity in an area, where the definition of the value of species diversity according to Shannon-Wiener is: $H' > 3$: High species diversity; $1 \leq H' \leq 3$: Medium species diversity; $H' < 1$: Low species diversity.

The species-evenness index analyzed species evenness (K) data referred to the Pielou Evenness Indices formula (Ludwig and Reynolds 1988); $E = H'/\ln S$. Where, E represents Evenness Index, and H' represents Shannon-Wiener Diversity Index. Margalef formula was used as Species Richness Index (Magurran 1988): $R_1 = \frac{(S-1)}{(\ln(N))}$, which R_1 represents the Richness Index, S for the Number of Species found, and N for the Total Number of Individuals.

Dominance data were analyzed using the Simpson formula: $D = \sum \frac{(n_i(n_i-1))}{(N(N-1))}$ D represents the Dominance Index, n_i for Number of Individuals belonging to species i , and N Total Number of Individuals. The results of the dominance index were grouped into $0 < D < 0.5$, in which no species dominate other species or a stable community structure. While index $0.5 < D < 1$, meaning some species dominate other species or a community structure is unstable because of ecological pressures (Odum 1971; Krebs 2014).

RESULTS AND DISCUSSION

Mudskipper fish at the research site

The species of mudskipper fish which were found comprised one Gobiidae Family of the Actinopterygii Class: *Periophthalmus argentilineatus*, *Periophthalmus kalolo*, *Periophthalmus malaccensis*, *Periophthalmus minutus*, and *Periophthalmus variabilis*. The total number of mudskipper fish found in Tomini Bay coastal mangrove area, is as many as 561 individuals. Spreading across station I at Dulupi village (156 individuals), station II at Bajo village (254 individuals), and station III at East Pentadu village (151 individuals). The classification of mudskipper fish in the coastal mangrove ecosystem of Tomini bay, Boalemo, Gorontalo Province, is presented in Table 1. Morphological appearance of each species can be seen in Figures 3 and 4.

The data of mudskipper fish at three locations showed moderate diversity with a value of H' : 1.09. The Evenness index was 0.99 based on three observation stations. The lowest dominance value was at station II with a value of 0.34 (Figure 5).

The morphological, morphometric and meristic characters of mudskipper fish

Table 2 shows the comparison of morphological characters of mudskipper fish in the coastal mangrove ecosystem of Tomini Bay, Indonesia. Table 3 shows the comparison of morphometric characters of mudskipper fish in the coastal mangrove ecosystem of Tomini Bay, Indonesia. The comparison of meristic characteristics of mudskipper fish which were found in the coastal mangrove ecosystem of Tomini Bay, Indonesia, along with the species' classification, are presented in Table 4 and Figures 3-4.

Environment parameters

Table 5 shows the range of temperature measurement at three research locations was around 28-30°C at station I (Dulupi), 29-30°C at station II (Bajo) and 28-30°C at station III (East Pentadu). The value of water's acidity degree (pH)

was in the range of 7.1-8, and the substrate (pH) was in the range of 6.8-8. Based on its visual look, the ecological condition of Station I (Dulupi) of the mangrove area was still considered good-solid, possessing sandy and muddy textures of ground habitat with mangroves growing on it. In Station II (Bajo), the mangrove area had been shift-transferred to a settlement area without considering the strong values of mangrove plants. Based on its visual look, the ground texture of the mangrove forest is sandy and muddy. Large rubbish was scattered, and many mangrove saplings died and were broken. In station III (East Pentadu), according to its visual appearance, the ground texture of the mangrove was muddy. However, the mangrove condition was still considered good, and the regeneration of the growing saplings in the area was considered quick and plenty.

Table 1. The classification of mudskipper fish in the coastal mangrove ecosystem of Tomini bay, Boalemo, Gorontalo Province, Indonesia

Class, Family	Species	Station			Total number of individuals
		I Dulupi	II Bajo	III East Pentadu	
Actinopterygii					
Gobiidae	<i>Periophthalmus argentilineatus</i>	-	-	83	83
	<i>Periophthalmus kalolo</i>	67	-	-	67
	<i>Periophthalmus malaccensis</i>	89	98	-	187
	<i>Periophthalmus minutus</i>	-	75	-	75
	<i>Periophthalmus variabilis</i>	-	81	68	149
Total					561

Note: (√) found; (-) Not found; the number in brackets represents the number of individuals observed

Table 2. Comparison of morphological characters of mudskipper fish in the coastal mangrove ecosystem of Tomini Bay, Boalemo, Gorontalo Province, Indonesia

Characters	Mudskipper fish				
	<i>P. minutus</i>	<i>P. malaccensis</i>	<i>P. variabilis</i>	<i>P. argentilineatus</i>	<i>P. kalolo</i>
Dermal cup	-	-	-	-	-
One row of teeth on the maxilla	+	+	+	+	+
Pelvic frenum	-	+	+	-	+
Pelvic fin wholly fused	-	-	-	-	-
Pelvic fin partly fused	-	+	+	-	+
Pelvic fin is not fused	+	-	-	+	-
High D1	-	-	-	-	-
Medium D1	+	+	+	+	+
Low D1	-	-	-	-	-
Slightly rounded D1 margins	-	+	-	-	-
Rounded D1 margin	-	-	+	-	+
Straight D1 margin	+	-	-	+	-
White D1 margin	-	-	+	-	+
Single inframarginal brown strip on D1	-	+	+	-	-
Single inframarginal black strip on D1	-	-	-	-	+
Single brown strip mesially on D1	+	-	-	+	-
White spot on proximal on D1	+	+	-	+	+
Reddish orange spot on D1	-	-	+	-	-
Elongated first spine on D1	-	+	+	-	-
Dusky strip mesially on D2	+	+	-	+	+
D1 and D2 connected by a membrane	-	-	-	-	-
Reddish orange pelvic and caudal fins	-	-	+	-	-

Table 3. Comparison of morphometric characters of mudskipper fish in the coastal mangrove ecosystem of Tomini Bay, Boalemo, Gorontalo Province, Indonesia

Characters (cm)	Mudskipper fish				
	<i>P. minutus</i>	<i>P. malaccensis</i>	<i>P. variabilis</i>	<i>P. argentilineatus</i>	<i>P. kalolo</i>
Pre-orbital length	0.051	0.029	0.035	0.061	0.037
Eye diameter	0.060	0.060	0.060	0.076	0.068
Head length	0.152	0.160	0.137	0.118	0.136
Snout length	0.273	0.274	0.264	0.247	0.256
Post-orbital length	0.506	0.070	0.054	0.091	0.055
Pre-dorsal length	0.337	0.383	0.368	0.384	0.346
Pre-ventral length	0.279	0.313	0.307	0.256	0.299
Pre-anal length	0.649	0.629	0.632	0.583	0.630
D1 base length	0.214	0.178	0.192	0.163	0.172
D1 longest spine length	0.195	0.237	0.196	0.164	0.233
D2 base length	0.216	0.174	0.216	0.201	0.211
Length of caudal pedunculus	0.172	0.163	0.164	0.175	0.143
Head height	0.157	0.159	0.162	0.187	0.142
Front body height	0.184	0.194	0.194	0.204	0.182
Pectoral fin's longest ray length	0.206	0.179	0.173	0.164	0.145
Middle body height	0.170	0.207	0.173	0.184	0.169
Pelvic fin base length	0.047	0.041	0.063	0.120	0.033
Pelvic fins' longest ray length	0.101	0.116	0.088	0.102	0.103
Caudal base height	0.160	0.165	0.162	0.162	0.142
Anal fin length	0.201	0.188	0.223	0.165	0.155
Anal fin's longest ray length	0.081	0.059	0.056	0.127	0.074
Caudal pedunculus height	0.081	0.097	0.099	0.101	0.082
Caudal fin height	0.144	0.162	0.115	0.145	0.152
Caudal fin length	0.213	0.234	0.208	0.219	0.167

Table 4. Comparison of meristic characters of mudskipper fish in the coastal mangrove ecosystem of Tomini Bay, Boalemo, Gorontalo Province

OTU	Number of spines and rays												LS
	D1		D2		A		P		V		C		
	S	R	S	R	S	R	S	R	S	R	S	R	
<i>Periophthalmus minutus</i>	16	0	1	12	0	11	0	13	0	6	0	13	60
<i>Periophthalmus malaccensis</i>	11	0	1	12	0	11	0	11	0	6	0	14	58
<i>Periophthalmus variabilis</i>	14	0	1	12	0	12	0	13	0	6	0	16	52
<i>Periophthalmus argentilineatus</i>	13	0	1	12	0	12	0	12	0	6	0	16	70
<i>Periophthalmus kalolo</i>	11	0	1	12	0	11	0	11	0	6	0	14	62

Table 5. Physics and chemical parameters of the waters study area

Environment parameters	Coastal mangrove area of Tomini Bay, Boalemo		
	Station I (Dulupi)	Station II (Bajo)	Station III (East Pentadu)
Temperature (°C)	28-30	29-30	28-30
Substrate	Sand and mud	Sand and mud	Mud
Water pH	7.1-8	7.3-8	7.3-8
Substrate pH	7.5-8	6.8-7	6.8-7.5

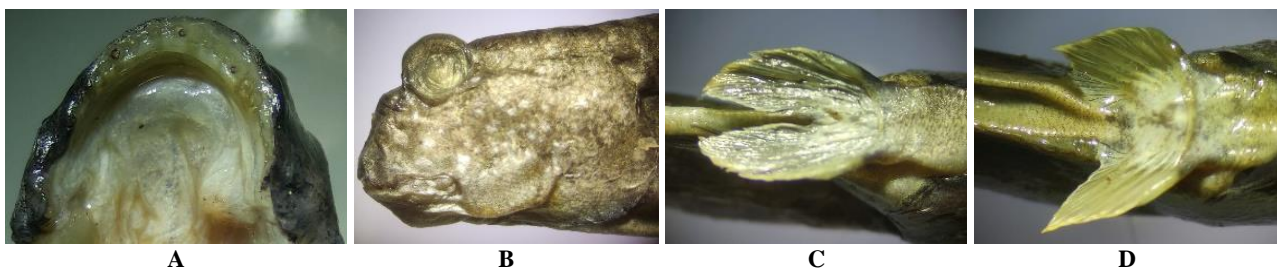
**Figure 3.** The characteristics of mudskipper fish in the coastal area of the mangrove ecosystem in Tomini Bay, Boalemo, Gorontalo Province, Indonesia: A. one-row teeth on maxilla; B. Dermal-Cup; C. Pelvic fin without frenum; D. Pelvic fin without frenum. A red arrow showed the frenum

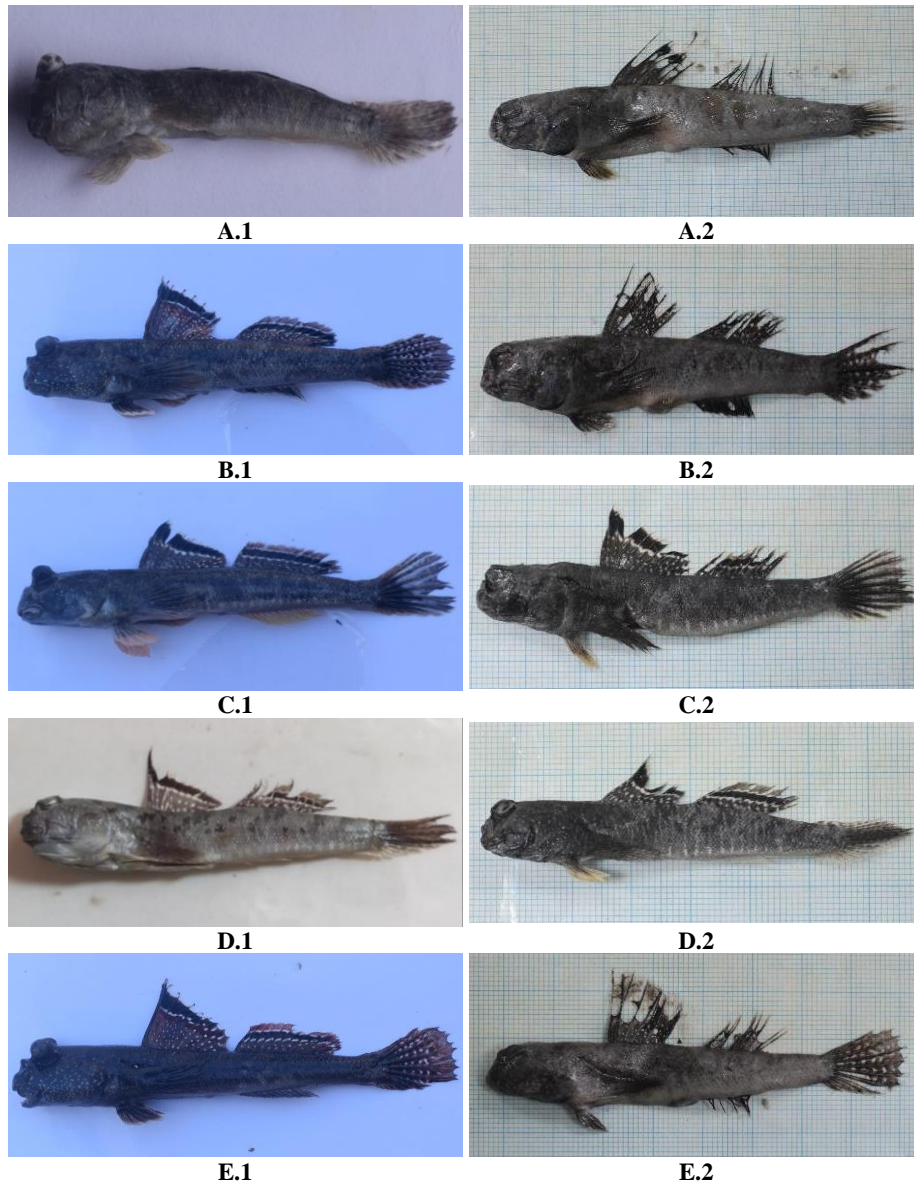

Figure 4. Mudskipper fish in the coastal mangrove ecosystem of Tomini Bay, Boalemo, Gorontalo Province, Indonesia. A. *Periophthalmus minutus*; B. *Periophthalmus malaccensis*; C. *Periophthalmus variabilis*; D. *Periophthalmus argentilineatus*; E. *Periophthalmus kalolo*. These specimens had been preserved under a -50°C temperature for one month

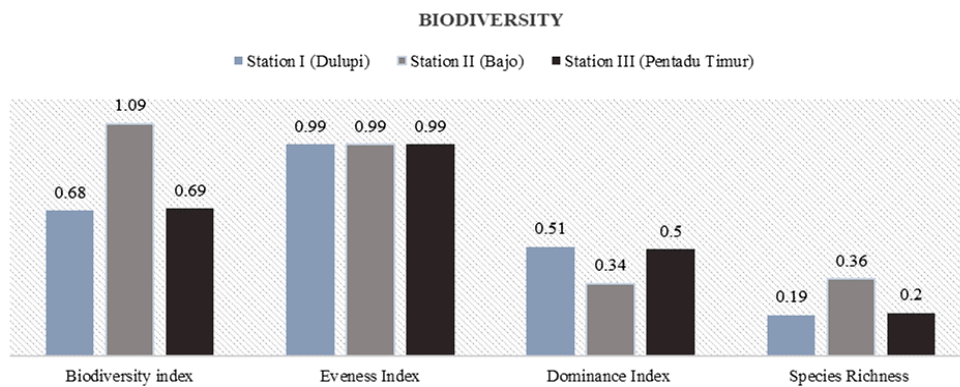

Figure 5. Biodiversity (Biodiversity index, Evenness Index, Dominance Index, and Species Richness) of mudskipper fish in the research site of Tomini Bay, Boalemo, Gorontalo Province, Indonesia

Discussion

Five species of mudskipper fish could be found in the coastal mangrove ecosystem of Tomini Bay, Boalemo, Gorontalo Province, in which all of the species were part of Genus *Periophthalmus*. It implied that mudskipper fish spread all over the tropical and subtropical habitat, except in the western tropical Atlantic and eastern tropical Pacific (Springer 1982; Jaafar and Murdy 2017). *Periophthalmus* tends to stay in mangrove ecosystems. That is due to the existence of many detritus, small crabs, small fish, shrimps, and arthropods in mangroves which are food for *Periophthalmus* (Rha'ifa et al. 2021). Thus, the result of this study was in line with previous studies conducted in the coastal ecosystems around Indo-Pacific (Pormansyah et al. 2019). Such as Maluku (Rumahlatu et al. 2020; Taniwel et al. 2020), South Sumatera (Ridho et al. 2019), West Nusa Tenggara (Rha'ifa et al. 2021), Yogyakarta (Arisuryanti et al. 2018), North Sulawesi (Polgar et al. 2017), Java and Bali (Dahrudin et al. 2017), Malacca Strait and Malay Peninsula (Polgar et al. 2014). Researchers found all species possessed high similarity in morphological features because they are part of the same Genus (Table 2).

Periophthalmus minutus

D₁ XVI, D₂ I, 12; A 11; P 13; V 6; C 13

Eyes without dermal cup; one row of teeth on the maxilla; pelvic fin without frenum; moderate D1 height with straight margins, single brown strip mesial with numerous proximal white spots, without spinal elongation; D2 with dusky brown stripe mesially; D1 and D2 are not connected by a membrane; lateral scales 60; head length 0.273% SL; pelvic fin basal length 0.047% SL; anal fin basal length 0.201% SL; D1 basal length 0.214% SL; D2 basal length 0.216% SL; caudal peduncle height 0.081% SL (Figure 2, Table 3, Table 4). In some conditions, the frenum can be seen through magnification (Jaafar and Murdy (2017).

Periophthalmus malaccensis

D₁ XI, D₂ I, 12; A 11; P 11; V 6; C 14

Eyes without dermal cup; one row of teeth on the maxilla; the pelvic is clear and prominent; moderate D1 height with slightly rounded margins, a single inframarginal brown strip with numerous proximal white spots. First spine elongated; D2 with faded brown stripe mesial; a membrane does not connect D1 and D2; lateral scales 58; head length 0.274% SL; pelvic fin basal length 0.027% SL; anal fin basal length 0.188% SL; D1 basal length 0.178% SL; D2 basal length 0.174% SL; caudal peduncle height 0.097% SL (Figure 2, Table 3, Table 4). Although *Periophthalmus malaccensis* has bright blue spots on the chin and operculum, it also has prominent transverse folds on the snout (Polgar 2016).

Periophthalmus variabilis

D₁ XI, D₂ I, 12; A 11; P 11; V 6; C 14

Eyes without dermal cup; one row of teeth on the maxilla; the pelvic frenum is clear and prominent; the pelvic is orange at least at the margins; moderate D1 height with rounded margins. A single inframarginal brown strip with many proximal white spots. The first spine elongated, white

margin; D2 with single inframarginal orange stripe and black single stripe mesial. Reddish-orange spots at the base; the anal fins are orange, at least at the margins. A membrane does not connect D1 and D2; lateral scales 52; head length 0.264% SL; pelvic fin basal length 0.027% SL; anal fin basal length 0.063% SL; D1 basal length 0.192% SL; D2 basal length 0.216% SL; caudal peduncle height 0.099% SL (Figure 2, Table 3, Table 4). When alive, the branchiostegal membrane of the fish shows pigmentation (Setiawan et al. 2019).

Periophthalmus argentilineatus

D₁ XIII, D₂ I, 12; A 12; P 12; V 6; C 16

Eyes without dermal cup; one row of teeth on the maxilla; pelvic without frenum; moderate D1 height with straight margins, single brown strip mesial with numerous proximal white spots, without spinal elongation; D2 with dusky brown stripe mesial; D1 and D2 are not connected by a membrane; lateral scales 70; head length 0.247% SL; pelvic fin basal length 0.12% SL; anal fin basal length 0.165% SL; D1 basal length 0.163% SL; D2 basal length 0.201% SL; caudal peduncle height 0.101% SL (Figure 2, Table 3, Table 4). The total transverse scale from ventroposterior D2 basal to the basal of the anal fin is 18-26 (Jaafar and Murdy 2017).

Periophthalmus kalolo

D₁ XI, D₂ I, 12; A 11; P 11; V 6; C 14

Eyes without dermal cup; one row of teeth on the maxilla; vestigial pelvic frenum; pelvic fins fused about half of the pelvic fins; moderate D1 height with rounded margins, Single black stripe inframarginal with proximal white spots, without spinal elongation; D2 with inframarginal dusky strip; D1 and D2 are not connected by a membrane; lateral scales 62; head length 0.256% SL; pelvic fin basal length 0.033% SL; anal fin basal length 0.155% SL; D1 basal length 0.172% SL; D2 basal length 0.211% SL; caudal peduncle height % SL (Figure 2, Table 3, Table 4). The total transverse scale from ventroposterior D2 basal to the basal of anal fin is fewer than *Periophthalmus argentilineatus*, which is only 18-22 (Jaafar and Murdy 2017).

Morphological adaptations of mudskipper fish created variations in morphometric and meristic measurements (Nugroho et al. 2016; Dinh et al. 2020; Ghanbarifardi et al. 2020). Jaafar and Murdy (2017) added that morphological characteristics such as the number of dorsal spines, the presence of finger-like projections in the maxillodentary ligament in the lip of the lower jaw and the epaxialis muscle attaching anteriorly of the frontal and epioccipital junction could distinguish genera in the Family. Meristic characters such as the scales before and after the pectoral filaments, pectoral fins, dorsal fins, abdominal fins, and anal fins are characters that can distinguish species in the Genus. In addition, other factors that influence differences in fish morphology are food availability, environmental conditions, and the stage of fish maturity. Another characteristic with a high probability of variation is coloration. Fish coloration is influenced by genetic, environmental, dietary, and physiological factors (Nüsslein-Volhard and Singh 2017). Due to the instability of the correlation character, this

characteristic is mostly neglected when identifying fish species.

Environmental conditions influence the difference in species diversity between the three stations. Many factors influence the high and low species diversity, and one of the factors is environmental quality. Krebs (2014) further explained that species diversity is used to measure the stability of a community which is the ability of a community to keep itself stable despite disturbances to its components. Maturbongs et al. (2018) argued that the area or mud substrate is a habitat for various nekton, which indicates the area has abundant food sources. The existence of habitat variations (substrate), such as physical conditions and the surrounding environment, affects the diversity of fish species. The diversity index at the research site was 1.09; this indicated that a high diversity level of mudskipper fish in the Coastal Bay of Tomini, Bualemo, was included in the moderate criteria. In addition, it also showed that water productivity was quite balanced.

The comparison of the Evenness index of mudskipper fish in the research locations had the same Evenness index value of 0.99. This value indicated that the evenness in the three locations was stable. The Evenness index shows the degree of evenness of individual abundance between each species. The community has a maximum Evenness value if each species has the same number of individuals. On the other hand, if the Evenness value is small, then the community has dominant, sub-dominant, and dominated species; eventually, the community has a minimum Evenness. The Evenness value had a range between 0-1; if the index value obtained was close to one, the distribution is more even (Ludwig and Reynolds 1988; Baderan et al. 2021). Figure 3 presents the index of evenness of the mudskipper (*Periophthalmus*) species in the Coastal Bay of Tomini, Bualemo, which was included in a stable community. Thus, the population between species of the genus *Periophthalmus* on the Coastal Bay of Tomini, Bualemo, was fairly even so that disturbances did not easily occur and were able to return to their initial conditions.

Species richness in the research locations was low with the Specific Richness Index (R1) at each station as follows 0.19 (Station I Dulupi), 0.36 (Station II Bajo), 0.2 (Station III East Pentadu). Species richness refers to the number of species in a community. The number of species in the field determines the size of the richness index. The Margalef richness index divides the number of species by the natural logarithm function meaning that the increase in the number of species is inversely proportional to the increase in the number of individuals. Generally, a community/ecosystem with abundant species will have a small number of individuals in each of these species.

The dominance of species in water often occurs due to several things, including competition for natural food by certain species accompanied by changes in environmental quality and an imbalance between predators and prey, resulting in competition between species. Maturbongs et al. (2018) explained that dominance occurs because of the result of the competition process for evicting one individual against another. Okyere (2018) stated that at low tide, the estuary area is dominated by brackish fish species, one of

which is from the Gobiidae family. This statement is true because mudskipper fish is more active during low tide conditions both on the coast and at an estuary; on the other hand, mudskipper fish will hide in their nests at high tide to avoid predators. The dominance index of mudskipper fish was 0.51, which indicated that the level of species dominance in these waters was moderate; thus, there were no dominant species in these waters.

Environmental factors that are very supportive and the absence of predators made several species of mudskipper fish thrive and spread across the area. In line with research by Mahadevan and Ravi (2015), which stated that the right water temperature range for mudskipper fish was between 23.5-35.5°C, the measurement results of environmental parameters showed that the average temperature range was 28-30°C. Furthermore, Bidawi et al. (2017) explained that mudskipper species had tolerance to wide changes in temperature and salinity, indicating that water temperature is one of the environmental factors that affect the spread and diversity of mudskipper species.

The pH content of the substrate ranged from 6.8 to 8. It means that the water conditions for the life of mudskipper fish were in the neutral range. The difference in soil pH at the research sites was caused by the contribution of leaf, root, and stem litter that fell to the ground and decomposed to form soil organic matter (Tajbakhsh et al. 2018). The substrate PH greatly affects the resistance of organisms that live at the bottom of the waters, both infauna and epifauna. That occurred due to the influence of tidal or brackish water during the formation of land and subsequent tidal processes. Furthermore, Kanejiya et al. (2017) explained that the distribution of mudskipper fish was significantly influenced by environmental factors such as pH, temperature, salinity, and other ecological conditions (Ghanbarifardi et al. 2014). Therefore, regarding the presence of mudskipper fish with substrate conditions in the mangrove area at the three stations, substrate differences play an important role in the distribution of mudskipper fish.

ACKNOWLEDGEMENTS

The authors would like to thank the Directorate of Research, Technology and Community Service, Directorate General of Higher Education, Research and Technology, which have funded research on the Basic Research of Higher Education (*Penelitian Dasar Unggulan Perguruan Tinggi*/PDUPT) scheme and Institute for Research and Community Service, the State University of Gorontalo, the Local Government of Boalemo and Pohuwato Districts have helped implement this research.

REFERENCES

- Akinrotimi OA, Edun OM, Uka A, Owhonda KN. 2012. Public perception of mudskipper consumption in some fishing communities of rivers state, Nigeria. *J Fish Aquat Sci* 8: 208-212. DOI: 10.3923/jfas.2013.208.212.
- Ansari AA, Trivedi S, Saggi S, Rehman H, Das M, Palita SK. 2014. Mudskipper: A biological indicator for environmental monitoring and

- assessment of coastal waters. *J Entomol Zool Stud* 2: 22-33. DOI: 10.22271/j.ent
- Arisuryanti T, Hasan RL, Koentjana JP. 2018. Genetic identification of two mudskipper species (Pisces: Gobiidae) from Bogowonto Lagoon (Yogyakarta, Indonesia) using COI mitochondrial gene as a DNA barcoding marker. *AIP Conf Proc* 2002: 020068. DOI: 10.1063/1.5050164.
- Aydalina RV. 2016. Morphological and Genetic Variations of Members of the Eleotridae Family in Lake Tondano and Limboto and Tapodu and Bolango Rivers, Noerth Sulawesi. [Thesis]. Universitas Gadjah Mada, Yogyakarta. [Indonesia]
- Baderan DWK, Rahim S, Angio M, Bin Salim AI. 2021. The diversity, evenness, and richness of plant species found on the potential geosite of otanaha fortress as a pioneer for geopark development in the province of Gorontalo. *Al-Kauniyah: Jurnal Biologi* 14: 264-274. DOI: 10.15408/Kauniyah.V14i2.16746. [Indonesia]
- Bidawi BM, Desrita D, Yunasfi Y. 2017. Hubungan panjang berat dan faktor kondisi ikan gelodok (Famili:Gobiidae) pada ekosistem mangrove di desa Pulau Sembilan Kabupaten Langkat Provinsi Sumatera Utara. *Depik* 6: 228-234. DOI: 10.13170/Depik.6.3.7029. [Indonesia]
- Chakraborty S, Saha SK, Ahmed SS. 2020. Recreational services in tourism dominated coastal ecosystems: Bringing the non-economic values into focus. *J Outdoor Recreat Tour* 30: 100279. DOI: 10.1016/J.Jort.2020.100279.
- Cooray PLIGM, Kodikara ASK, Kumara MP, Jayasinghe UI, Madarasinghe SK, Dahdouh-Guebas F, Gorman D, Huxham M, Jayatissa LP. 2021. Climate and intertidal zonation drive variability in the carbon stocks of Sri Lankan mangrove forests. *Geoderma* 389: 114929. DOI: 10.1016/j.geoderma.2021.114929.
- Dahrudin H, Hutama A, Busson F, Sauri S, Hanner R, Keith P, Hadiaty R, Hubert N. 2017. Revisiting the ichthyodiversity of Java and Bali through DNA barcodes: taxonomic coverage, identification accuracy, cryptic diversity and identification of exotic species. *Mol Ecol Resour* 17: 288-299. DOI: 10.1111/1755-0998.12528.
- Dinh QM, Tran LT, Ngo NC, Pham TB, Nguyen TTK. 2020. Reproductive biology of the unique mudskipper *Periophthalmodon septemradiatus* living from estuary to upstream of the Hau River. *Acta Zool* 101: 206-217. DOI: 10.1111/azo.12286.
- Fachrul MF. 2012. Metode Sampling Bioekologi. Bumi Aksara, Jakarta.
- Faridah-Hanum I, Hakeem ARKL, Ozturk M. 2014. Mangrove Ecosystems of Asia (Status, Challenges, and Management Strategies). Springer, New York.
- Fishbase. 2022. *Periophthalmus*. www.fishbase.org/Nomenclature/ScientificNameSearchList.php?
- Ghanbarifardi M, Aliabadian M, Esmaili HR. 2018. Phylogeography of walton's mudskipper, *Periophthalmus waltoni* Koumans, 1941 (Perciformes: Gobiidae), from the Persian Gulf and Gulf of Oman. *Zool Middle East* 64: 207-218. DOI: 10.1080/09397140.2018.1470300.
- Ghanbarifardi M, Aliabadian M, Esmaili HR. 2020. Shape variation of the Indian Ocean slender mudskipper, *Scartelaos tenuis* (Day, 1876) from the Persian Gulf and Oman Sea (Gobioidae: Gobiidae). *Iran J Fish Sci* 19: 612-622. DOI: 10.22092/ijfs.2018.119368.
- Ghanbarifardi M, Aliabadian M, Esmaili HR, Polgar G. 2014. Morphological divergence in the Walton's Mudskipper, *Periophthalmus waltoni* Koumans, 1941, from the Persian Gulf and Gulf of Oman (Gobioidae: Gobiidae). *Zool Middle East* 60: 133-143. DOI: 10.1080/09397140.2014.914717.
- Gonzalez-Martinez A, Lopez M, Molero HM, Rodriguez J, González M, Barba C, García A. 2020. Morphometric and meristic characterization of native chame fish (*Dormitator latifrons*) in ecuador using multivariate analysis. *Animals* 10: 1805. DOI: 10.3390/ani10101805.
- Hai NT, Dell B, Phuong VT, Harper RJ. 2020. Towards a more robust approach for the restoration of mangroves in Vietnam. *Ann For Sci* 77: 18. DOI: 10.1007/s13595-020-0921-0.
- Hidayat S, Wicaksono A, Raharjeng A, Jin DSM, Alam P, Retnoaji B. 2022. The morphologies of mudskipper pelvic fins in relation to terrestrial and climbing behaviour. *Proc Zool Soc* 75: 83-93. DOI: 10.1007/s12595-021-00422-1.
- Huang MC. 2013. Mudskippers in Tainan: The ecology and lifestyle of mudskipper *Periophthalmus modestus* in Tainan coastal wetland. *Intl J Sci Eng* 3: 37-43. DOI: 10.6159/IJSE.2013.(3-4).05.
- Hui NY, Mohamed M, Ammin OMN, Tokiman L. 2019. Diversity and behaviour of mudskippers of Tanjung Piai, Pontian, Johor. *IOP Conf Ser Earth Environ Sci* 269: 012037. DOI: 10.1088/1755-1315/269/1/012037.
- Jaafar Z, Murdy EO. 2017. *Fishes out of Water* (1st Ed.). CRC Press, United States.
- Jaafar Z, Polgar G, Zamroni Y. 2016. Description of a new species of *Periophthalmus* (Teleostei: Gobiidae) from the Lesser Sunda Islands. *Raffles Bull Zool* 64: 278-283. DOI: 10.5281/zenodo.5355323.
- Kanejiya JR, Solanki DA, Gohil BM. 2017. Distribution of mudskippers in the mudflats of hathab coast, Gujarat, India. *Cibtech J Zool* 6: 1-9.
- Kaur V, Ana Y, Heer BK. 2019. Morphometric analysis of fish, *Labeo rohita* (Hamilton) from pond near Kalayat, Kaithal, Haryana India. *J Fish Aquat Stud* 7: 299-306. DOI: 10.22271/fish.
- Krebs CJ. 2014. *Ecology: The Experimental Analysis of Distribution and Abundance* (6th Ed.). Pearson, USA.
- Lapolo N, Utina R, Baderan DWK. 2018. Diversity and density of crabs in degraded mangrove area at Tanjung Panjang nature reserve in Gorontalo, Indonesia. *Biodiversitas* 19 (3): 1154-1159. DOI: 10.13057/biodiv/d190351.
- Larson HK, Murdy EO. 2001. *The Living Marine Resources of the Western Central Pacific Volume 6: Bony Fishes Part 4 (Labridae to Latimeriidae), Estuarine Crocodiles, Sea Turtles, Sea Snakes and Marine Mammals*. Food and Agriculture Organization of the United Nations, Rome.
- Latuconsina H. 2016. *Ekologi Perairan Tropis: Prinsip Dasar Pengelolaan Sumberdaya Hayati Perairan*. Gadjah Mada University Press, Yogyakarta.
- Ludwig JA, Reynolds JF. 1988. *Statistical Ecology A Primer on Methods and Computing*. John Wiley & Sons, New York.
- Magurran AE. 1988. *Ecological Diversity and Its Measurement*. Princeton University Press, USA.
- Mahadevan G, Polgar G, Murugesan P. 2019. First record of the mudskipper *Periophthalmus walailakae* (Gobiidae) from southeast India. *Cybio Intl J Ichthyol* 43 (4): 373-375. DOI: 10.26028/cybio/2019-434-007.
- Mahadevan G, Ravi V. 2015. Distribution of mudskippers in the mudflats of muthupet, Southeast coast of India. *Intl J Fish Aquat Stud* 3: 268-272. DOI: 10.26028/cybio/2019-434-007.
- Maryam A, Saeid EP, Hosein R. 2015. Partial morphometrics and meristic evaluation of the two species mudskippers: *Scartelaos tenuis* (Day, 1876) and *Periophthalmus waltoni* (Koumans, 1941) from the Persian Gulf, Bushehr, Iran. *Intl J Fish Aquat Stud* 2: 353-358. DOI: 10.22271/fish.
- Maturbongs MR, Elviana S, Sunarni S, deFretes D. 2018. Studi keanekaragaman ikan gelodok (Famili: Gobiidae) pada muara Sungai Maro dan kawasan mangrove Pantai Kembapi, Merauke. *Depik* 7: 177-186. DOI: 10.13170/depik.7.2.9012. [Indonesia]
- Mukharomah E, Madang K, Santoso LM. 2016. Morphology and interspecific variation of mudskipper fish (*Periophthalmus gracilis* and *Periophthalmus variabilis*) in the Makarti Jaya and Sungsang; and its contribution to the biology courses at high school. *Proc Natl Educ Conf* 1: 267-276.
- Murdy EO. 1989. A taxonomic revision and cladistic analysis of the oxudercine gobies (Gobiidae: Oxudercinae). *Rec Aust Mus Suppl* 11: 1-93. DOI: 10.3853/j.0812-7387.11.1989.93.
- Nugroho ED, Rahayu DA, Rupa D. 2016. Studi morfologi ikan mudskippers (Gobiidae: Oxudercinae) sebagai upaya karakterisasi biodiversitas lokal Pulau Tarakan. *Jurnal Harpodon Borneo* 9: 46-56. DOI: 10.35334/harpodon.v9i1.49. [Indonesia]
- Nüsslein-Volhard C, Singh AP. 2017. How fish color their skin: A paradigm for development and evolution of adult patterns. *BioEssays* 39: 1600231. DOI: 10.1002/bies.201600231.
- Nguyen TP, Parnell KE. 2017. Gradual expansion of mangrove areas as an ecological solution for stabilizing a severely eroded mangrove dominated muddy coast. *Ecol Eng* 107: 239-243. DOI: 10.1016/j.ecoleng.2017.07.038
- Odum EP. 1971. *Fundamental of Ecology*. WB Saunders Company, Philadelphia, London, Toronto.
- Okyere I. 2018. Influence of diurnal tides and other physico-chemical factors on the assemblage and diversity of fish species in River Pra Estuary, Ghana. *Trop Ecol* 59: 83-90.
- Paino C. 2020. *Teluk Tomini Kehilangan Mangrove Akibat Alih Fungsi Lahan*. www.Mongabay.Co.Id/2020/07/27/Teluk-Tomini-Kehilangan-Mangrove-Akibat-Alih-Fungsi-Lahan/.
- Polgar G. 2016. First record and conservation value of *Periophthalmus malaccensis* Eggert from Borneo, with ecological notes on other

- mudskippers (Teleostei: Gobiidae) in Brunei. *Scientia Bruneiana* 15: 48-57. DOI: 10.46537/scibru.v15i0.42.
- Polgar G, Ghanbarifardi M, Milli S, Agorreta A, Aliabadian M, Esmaeili HR, Khang TF. 2017. Ecomorphological adaptation in three mudskippers (Teleostei: Gobiidae: Gobiidae) from the Persian Gulf and the Gulf of Oman. *Hydrobiologia* 795: 91-111. DOI: 10.1007/s10750-017-3120-8.
- Polgar G, Jaafar Z, Konstantinidis P. 2013. A new species of mudskipper, *Boleophthalmus poti* (teleostei: gobiidae: oxudercinae) from the gulf of Papua, Papua New Guinea, and a key to the genus. *Raffles Bull Zool* 61: 311-321.
- Polgar G, Zaccara S, Babbucci M, Fonzi F, Antognazza CM, Ishak N, Sulaiman Z, Crosa G. 2017. Habitat segregation and cryptic adaptation of species of *Periophthalmus* (Gobiidae: Gobiidae). *J Fish Biol* 90: 1926-1943. DOI: 10.1111/jfb.13276/
- Polgar G, Zane L, Babbucci M, Barbisan F, Patarnello T, Rüber L, Papetti C. 2014. Phylogeography and demographic history of two widespread Indo-Pacific mudskippers (Gobiidae: Periophthalmus). *Mol Phylogenet Evol* 73: 161-176. DOI: 10.1016/j.ympev.2014.01.014.
- Pormansyah IM, Setiawan A, Yustian I, Zulkifli H. 2019. A review of recent status on Mudskippers (Oxudercine Gobies) in Indonesian Waters. *Oceanogr Fish Open Access J* 9: 555769. DOI: 10.19080/OFOAJ.2019.09.555769.
- Ravi V. 2013. Food and Feeding Habits of the Mudskipper, *Boleophthalmus boddarti* (Pallas, 1770) from Pichavaram Mangroves, Southeast Coast of India. *Intl J Mar Sci* 3 (12): 98-104. DOI: 10.5376/ijms.2013.03.0012.
- Rha'ifa FA, Audrea DJ, Hakim L, Arisuryanti T. 2021. DNA barcode of barred mudskipper (*Periophthalmus argentilineatus* Valenciennes, 1837) from Tekolok Estuary (West Nusa Tenggara, Indonesia) and their phylogenetic relationship with other Indonesian Barred Mudskippers. *J Trop Biodivers Biotechnol* 6: 59702. DOI: 10.22146/jtbb.59702.
- Ridho MR, Patriono E, Solikha M. 2019. Food habits of three species of mudskippers in the Musi River Estuary, South Sumatra, Indonesia. *Biodiversitas* 20 (8): 2368-2374. DOI: 10.13057/biodiv/d200835.
- Rumahlatu D, Sangur K, Leuwol AP, Apituley YN, Salmanu SIA, Arini I. 2020. Study of environmental conditions, morphometric and meristic of Mudskipper (*Periophthalmus*) from Ambon Island Coastal Periophthalmus Waters, Indonesia. *Indian J Ecol* 47: 782-787.
- Rupp H. 2021. Submerged spawning and larval dispersal of the mudskipper *Periophthalmus variabilis*. *Aquat Biol* 30: 113-118. DOI: 10.3354/ab00745.
- Sellang H. 2020. Biologi Perairan. Penerbit Lakeish, Jakarta.
- Setiawan A, Iqbal M, Priscillia B, Pormansyah P, Setiawan D, Yustian I. 2019. Linking a gap, First record of dusky-gilled mudskipper *Periophthalmus variabilis* Eggert, 1935 (Perciformes: Gobiidae) in southern Sumatra, Indonesia. *Ecologica Montenegrina* 24: 11-16. DOI: 10.37828/em.2019.24.3.
- Shannon CE, Wiener W. 1963. *The Mathematical Theory of Communication*. The University of Illinois Press, Illinois.
- Springer VG. 1982. *Pacific Plate Biogeography, with Special Reference to Shorefish*. Smithsonian Institution Press, Washington DC.
- Tajbakhsh F, Stepien CA, Abdoli A, Tabatabaei N, Kiabi BH. 2018. Geometric morphometric and meristic analysis of the deepwater goby, *Ponticola bathybius* (Kessler, 1877) (Teleostei: Gobiidae) in the Iranian waters of the Caspian Sea. *Iran J Ichthyol* 5: 64-73. DOI: 10.22034/iji.v5i1.257.
- Taniwel D, Leiwakabessy F, Rumahlatu D. 2020. Short communication: Density and length-weight relationship of mudskipper (*Periophthalmus* spp.) in the mangrove area of Kairatu Beach, Maluku, Indonesia. *Biodiversity* 21 (11): 5465-5473. DOI: 10.13057/biodiv/d211155.
- Wicaksono A, Hidayat S, Damayanti Y, Jin DSM, Sintya E, Retnoaji B, Alam P. 2016. The significance of pelvic fin flexibility for tree climbing fish. *Zoology* 119: 511-517. DOI: 10.1016/j.zool.2016.06.007.
- WoRMS 2018. WoRMS Taxon Details: *Periophthalmus*. <https://marinespecies.org/aphia.php?p=taxdetails&id=0205192>.